

# GEM-II (1/2") GEM-I (1/3") Info

## Dimensions: mm

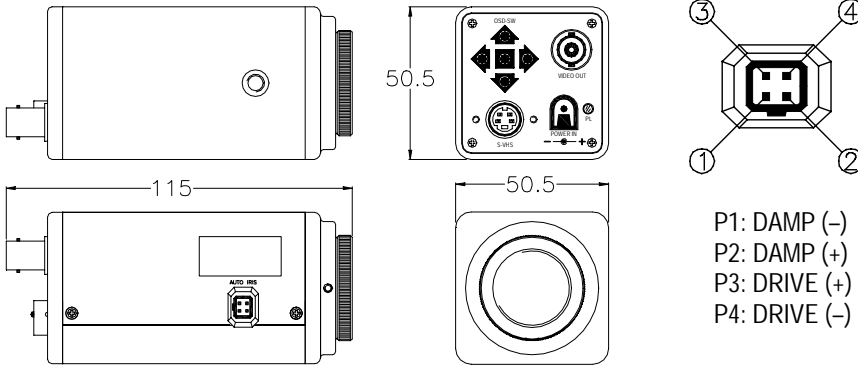

- P1: DAMP (-)
- P2: DAMP (+)
- P3: DRIVE (+)
- P4: DRIVE (-)

## SPECIFICATIONS

CATALOGUE CODE:.		CCS-GEM-I	CCS-GEM-I
TV SYSTEM		NTSC	PAL
IMAGE SENSOR		1/3 inch	
CCD TOTAL PIXELS		811(H) X 508(V)	795(H) X 596(V)
SCANNING SYSTEM		525 lines, 60 fields/sec	625 lines, 50 fields/sec
SYNC SYSTEM		Internal	
MINIMUM ILLUMINATION	Ordinary mode	0.8 Lux @ F1.2, 5600°K 30 IRE	
	Frame Integration	0.015 Lux @ F 1.2, 5600°K 10 IRE	
RESOLUTION		600 + Horizontal Lines	
WHITE BALANCE	Mode	ATW / AWB / FIX (Zero colour rolling)	
	Range	3200 - 10000 °K	
GAIN CONTROL	Mode	AGC (ON / OFF)	
	Range	0 - 18dB	
Signal : Noise Ratio		52dB (Minimum) / 60dB (Typical) measured with AGC Off	
AUTOMATIC ELECTRONIC SHUTTER		1/60-1/120,000 sec.	1/50-1/120,000 sec.
EXPOSURE CONTROL		A. E. S. / Direct Drive (DC) AI Lens	
OSD DISPLAY		ON SCREEN DISPLAY FOR ALL CONTROL	
5 PUSH BUTTON SWITCHES		FOR OSD CONTROL PANEL	
MIRROR FUNCTION		SELECTABLE BY OSD MANUAL	
UP SIDE DOWN		SELECTABLE BY OSD MANUAL	
B.L.C. FUNCTION		SELECTABLE BY OSD MANUAL	
DIGITAL ZOOM (2X)		SELECTABLE BY OSD MANUAL	
NEGATIVE IMAGE		SELECTABLE BY OSD MANUAL	
MASKING AREA		SELECTABLE BY OSD MANUAL	
WIDE DYNAMIC		48dB (280:1)	
VIDEO OUTPUT		Composite 1.14 V p-p at 75 ohms & Y/C S-Video	
POWER SUPPLY		12 Volts DC Regulated, ~ 250 mA, 2.1 x 5.5 mm Plug, center pin = (+)	

# On Screen Display (OSD) MAP

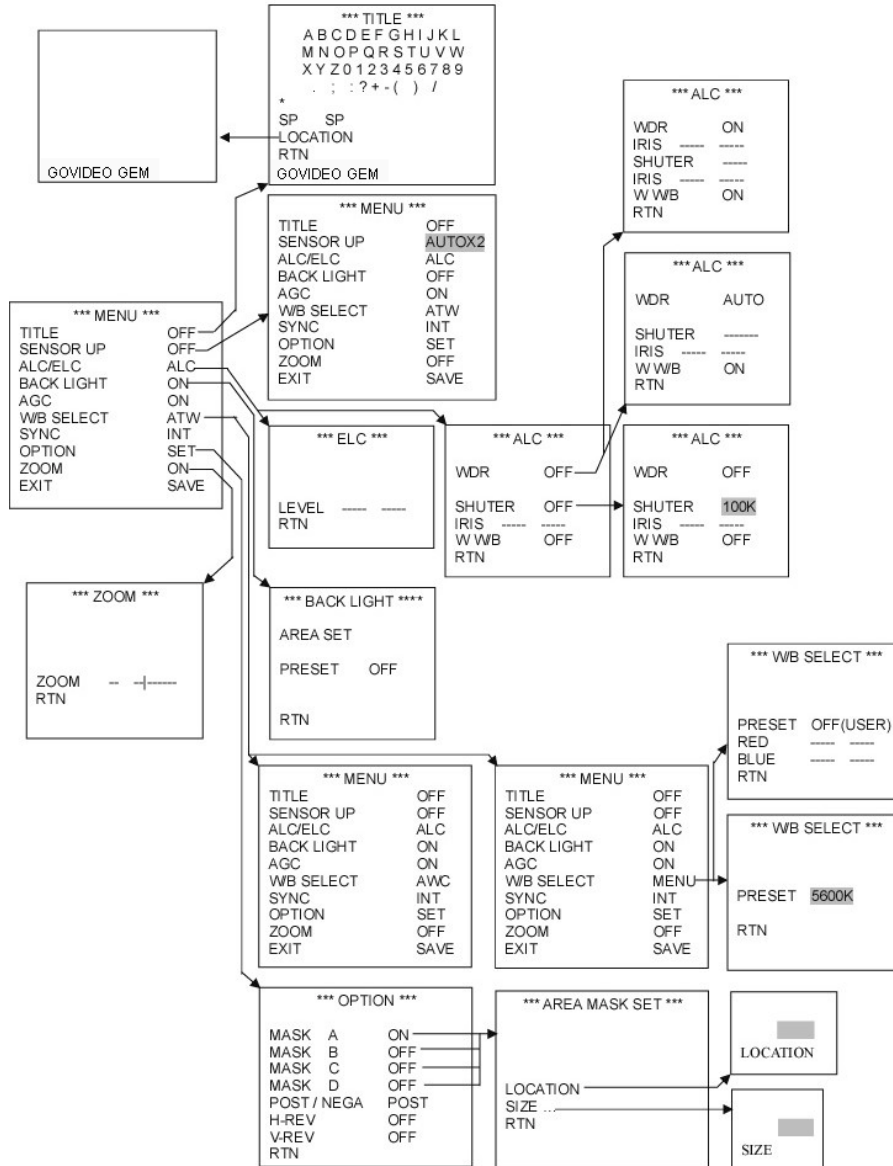

## Tutorial for OSD

There are 5 push buttons, push and hold in the center button for 2 seconds to display the menu.

### 1. Title

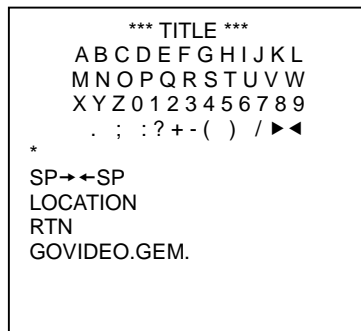
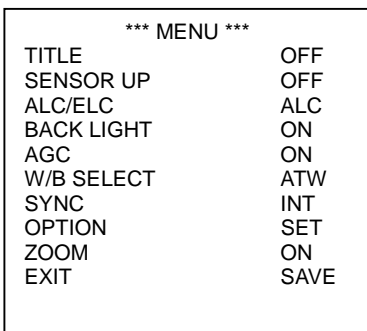

You can enter a Title and display it on the screen.

Move cursor to "Title" row, push right button to change from "off" mode to "on" mode. Push center button one more time and "Title" menu will be displayed. Choose a Title and move cursor around alphabet, push center button to enter the character, when finished, move cursor to "location" row then push center button once. The name you entered will be displayed on the screen, push "up" "down" "left" "right" buttons to move Title around the screen. When finished move cursor to "RTN", push center button once to go back to "Title" menu. Move cursor again to "RTN" in the menu, push center button once more to return to main Menu.

2. **Sensor up – Frame Integration**

*** MENU ***	
TITLE	OFF
SENSOR UP	AUTOX2
ALC/ELC	ALC
BACK LIGHT	OFF
AGC	ON
W/B SELECT	ATW
SYNC	INT
OPTION	SET
ZOOM	OFF
EXIT	SAVE

Sensitivity may be increased by using Frame Integration mode.

Move cursor to "Sensor up" row. Press "right" or "left" button to choose how much frame integration you want and the sensitivity of the camera will be increased. At the maximum of 62X the sensitivity will go up to 0.007 / 0.015 lux. Due to the nature of frame integration as sensitivity is increased the frame refresh rate will decrease.

3. **ALC / ELC**

*** MENU ***	
TITLE	OFF
SENSOR UP	AUTOX2
ALC/ELC	ALC
BACK LIGHT	OFF
AGC	ON
W/B SELECT	ATW
SYNC	INT
OPTION	SET
ZOOM	OFF
EXIT	SAVE

To Choose exposure mode.

There are two exposure control modes on this camera:  
ELC mode is mainly for scientific, industrial and medical use.  
ALC mode for most surveillance purposes.

**ELC mode**

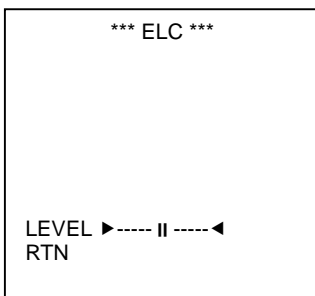

Move cursor to ALC/ELC row, push right button to select ELC mode. Push center button to enter ELC menu. In the ELC menu you may move "LEVEL" bar to vary exposure. This mode is mainly for scientific and industrial purposes and would not usually be used for surveillance purposes.

### ALC mode.

The "Super Wide Dynamic" mode may be set to on / off or auto mode.

"Off" mode selects "Super Smear Rejection" mode, "Auto" selects "Super Wide Dynamic" mode with the CPU choosing optimum exposure. "On" mode allows user to tailor exposure style to suit difficult lighting situations with "Wide Dynamic" feature.

### Auto - fully automatic Super Wide Dynamic mode

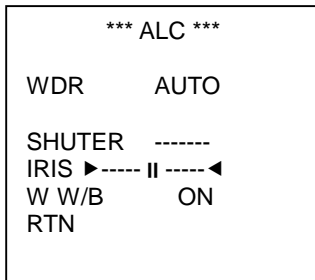

In Auto mode CPU controls most settings however you can still choose Auto Iris level to optimize the exposure from 70 IRE to 150 IRE and choose to use normal or dual white balance mode. Dual white balance mode will give bright and dark zones separate white balance algorithms as it is likely that colour temperature of indoor and outdoor lighting will be different. For example an incandescent lamp indoors and daylight outdoors.

### On - Super Wide Dynamic mode

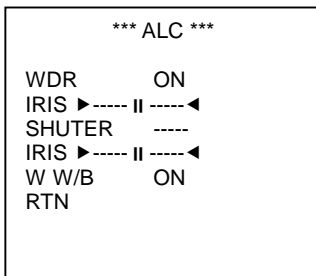

In this mode you can set the weighting of bright and dark zones to produce the best image. You can choose a different IRIS range to optimise the aperture and use "W W/B" to select from single or dual white balance mode. Dual white balance mode provides independent white balance algorithms for bright and dark zones and optimises colour rendering instead of compromising indoor and outdoor colour temperature like an ordinary camera. You will not be able to change the shutter speed because CPU has control of it.

### Off - Super Smear Rejection mode !

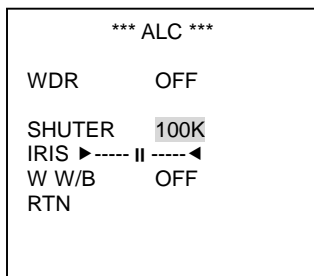

**This is probably the most exciting Mode !!**

"Off" mode turns the camera into a "Super Smear Rejection" camera. As there are two image memories in the camera for the purpose of super wide dynamic processing. User can choose to turn off the "Super Wide Dynamic" mode and use the same memory for the purpose of "Super Smear Rejection". The camera will then be upgraded to a 154 dB smear rejection ratio camera (compared to 95 ~ 110 dB for an ordinary camera). The camera can be used with scenes lit by direct sunlight without an auto iris lens and still produce good smear free images. If used to observe cars with headlights on during the night this camera will cancel the smear created by the bright headlights and produce a clear image of the driver's face. An ordinary camera has 95 ~ 110 dB smear rejection ratio and can only be operated with a shutter speed below approximately 1/2,000 second, from approximately 1/3,000 second and up to 1/100,000 ordinary cameras exhibit very obvious smear effects and the image is essentially useless. However GEMs will work from 1/2 to 1/100,000 second without smearing. In this mode you can still choose a different shutter speed and auto iris range to optimise the image. Many users find that this mode is even more useful than the Super Wide Dynamic mode as camera can be used Day and Night without an expensive auto iris lens. However if equipped with a good auto iris lens the static dynamic range will be further extended to 40,000,000. This dynamic range will allow the camera to handle scenes lit by direct sunlight to moonlight and still produce images with correct exposure and colour rendition. Moreover when the Lens Iris closes with daylight the depth of field will increase significantly.